

Torque Measuring Flange

Type 4504A...

Short Profile, Robust, Bearingless, High Accuracy

Type 4504A... torque measuring flanges operate on the strain gage principle. The integral, digital measurement preconditioning system produces analog or digital output signals, which are transmitted without contact. The rotor runs in the stator ring without mechanical bearings and is therefore free from wear.

- Accuracy class 0.1 and 0.05 for frequency and voltage output available
- Dust and moisture proofed magnetic speed/angle acquisition system with high resolution (adjustable up to 3,600 pulses/rev.)
- Identification, parameterization, measuring and zero point taring via RS-232C is standard
- Non-sensitive in critical built-in situations, that means no field absorbability at rotor excitation by metal components in close proximity
- Very short axial dimensions
- Compact flange-to-flange solution
- Digital non-contact signal transmission
- Maintenance-free, bearingless
- Electrical control signal to test sensor functions
- Conforming to CE

Description

Type 4504A... torque measuring flange was designed to be a very short flange-to-flange solution and its rotor can be installed from one side (normally the test specimen side), straight to the flange of the loading machine. This allows easy, cost-effective assembly into a power train. Speed acquisition system is fully integrated within sensor construction.

The torque flange can be mounted directly to the loading machine. Stator ring is positioned over the rotational rotor and will be maintained with the stator substructure.

Geometry, dimensions, materials, measuring system and signal transmission are designed especially for raw and complex applications in engine test rigs.



Options

- Frequency output
- Speed measurement up to 3,600 pulses/rev. and 2,560 pulses/rev. (Track A and B)
- Rotational angle measurement, resolution up to 0.02° (Track A and B)
- Separate output signal to connectors C and D
- Calibrated RS-232C output

Application

The extremely narrow profile of the Type 4504A... torque measuring flange makes it very suitable for many test rig applications: Test bed for engines, dynamometer, wheel load simulation, gear boxes, pumps, electric motors and many others.

Technical Data

Mechanical Basic Data

Type 4504A...			...50...	...100...	...200...	...500...	...1000...	...2 000...	...3 000...	...5 000...
Measuring range (nominal torque)	M_{nom}	lbf-ft	36.9	73.8	147.5	368.8	737.6	1,475.2	2,212.8	3,688
Limiting torque	M_{op}	lbf-ft	73.8	147.5	295	737.6	1,475.2	2,950.4	4,425.6	7,376
Rupture torque	M_{rupt}	lbf-ft	>147.5	>295	>590.1	>1,475.2	>2,950.4	>5,900.8	>8,851.2	>14,752
Alternating torque	M_{dyn}	lbf-ft	36.9	73.8	147.5	368.8	737.6	1,475.2	2,212.8	3,688
Nominal speed	n_{nom}	rpm	15,000	15,000	15,000	12,000	12,000	10,000	10,000	8,000
Torsional rigidity	C_T	klbf-in/rad	504.5	1,876.2	3,495.8	12,390	22,656	62,835	88,500	132,750
Rotation angle at M_{nom}	φ	°	0.05	0.027	0.029	0.020	0.023	0.016	0.017	0.019
Max. bending moment	M_B	lbf-ft	36.9	51.6	103.3	368.8	368.8	737.6	1,180.2	1,844
Max. axial force	F_A	lbf	449.6	449.6	899.2	1,573.7	1,573.7	2,697.7	3,147.3	4,945.8
Max. radial force	F_Q	lbf	179.8	224.8	674.4	1,348.9	1,798.5	3,372.1	4,046.6	6,744.3
Rotor weight	m_{rotor}	kg	0.8	0.85	1.4	3.00	3.11	4.7	6.60	11.30
Stator weight	m_{stator}	kg	1.2	1.2	1.6	2.10	2.11	2.5	2.50	4.38
Moment of inertia (rotor)	j_{rotor}	lbf-ft ² ·10 ⁻³	28.4	30.8	78.1	272.2	275.5	667.4	899.3	2,349.7
Partial mass of the rotor (measurement side) also for option N1, N2	$m_{rotor-M}$	kg	0.33	0.35	0.40	1.00	1.10	2.2	2.80	4.90
Partial moment of inertia of the rotor (measurement side) also for option N1, N2	j_{N1-M}	lbf-ft ² ·10 ⁻³	11.4		22.5	89.9	94.7	310.0	397.6	899.8
Balancing class	Q		6.3							
Housing material			Hard anodized aluminum							
Protection class			IP54							

General Electrical Specifications

Output signal (rated value)	VDC	±10 (and others as an option)
Supply voltage	VDC	11 ... 30
Power consumption	W	<5
Load resistance	kΩ	>10
Limit frequency –3 dB	kHz	1
100 % control input	VDC	"On" 3.5 ... 30 "Off" 0 ... 2
Control signal	% FSO	100

Electrical Measuring Data

Accuracy class		0.1/opt. C1: 0.05
Linearity error including hysteresis	% FSO	0.1/opt. C1: 0.05
Temp. influence on the zero point	% FSO/°F	0.003
Temp. influence on the nominal value	% FSO/°F	0.003
Max. deviation with bending moment	% FSO/lbf-ft	0.009
Max. deviation with axial force	% FSO/lbf	0.00064
Max. deviation with radial force	% FSO/lbf	0.00055
NP stability (for 24 h)	% FSO	0.03

Reference temperature	°F	72 ±2
Operating temperature range (Rated temperature range)	°F	50 ... 140
Service temperature range	°F	32 ... 158
Storage temperature range	°F	–13 ... 176

Speed Measurement

Speed measurement option N1		
Pulse number		1x60
Max. distance from rotor to probe	in	0.1
(adjustable)		
Speed measurement option N2		
Pulse number (Track A and B)		2x720
Max. distance from rotor to probe	in	0.04
(adjustable)		
Speed measurement option N3		
Pulse number (Track A and B)		2x1 024
Max. distance from rotor to probe	in	0.04
(adjustable)		

Dimensions

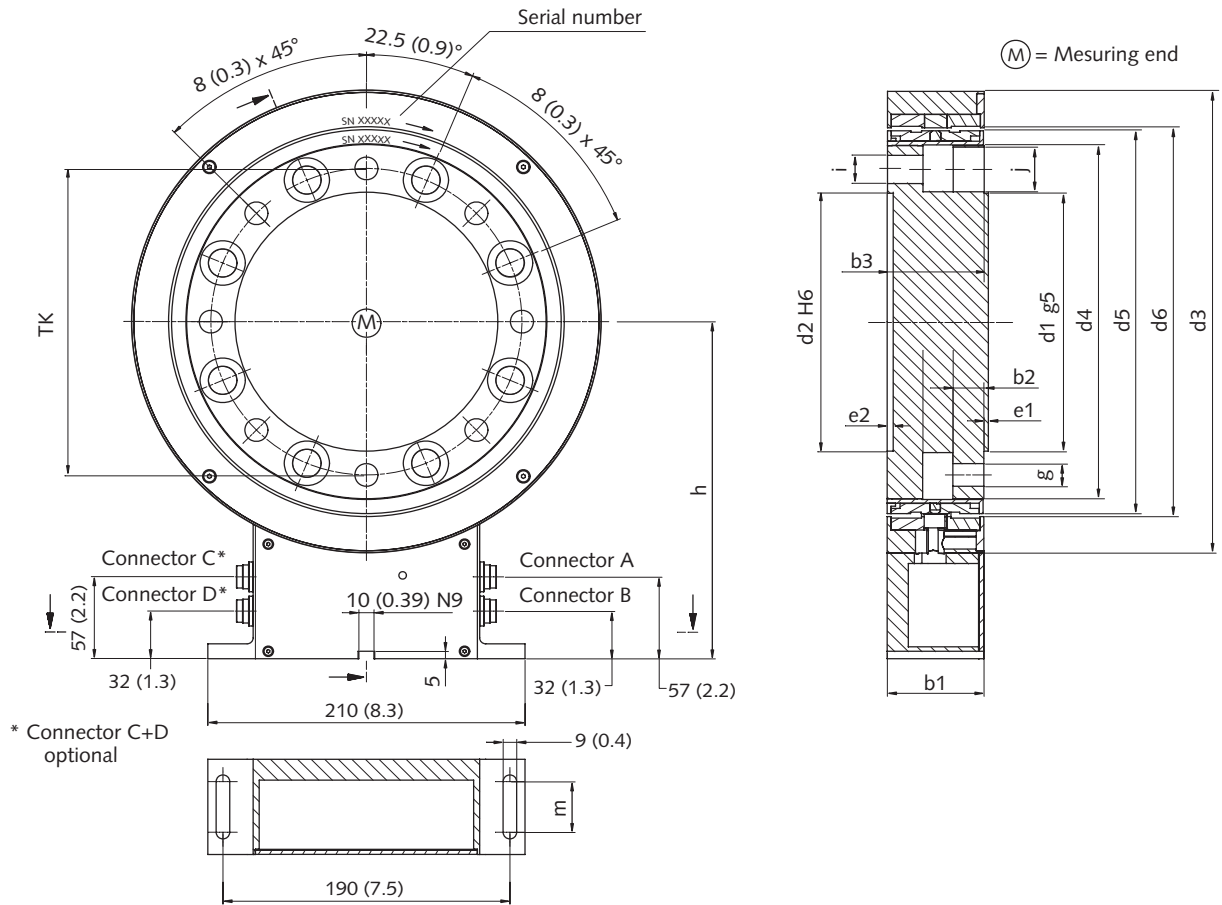

Dimensions in mm

Size	Measuring range lbf-ft	b1	b2	b3	e1	e2	ød1 g5	ød2 H6	ød3	ød4	ød5	ød6	TKø	g	h	øi	øj	m
1	36.9	1.6	0.26	1	0.12	0.10	3.0	3.0	6.8	3.9	4.7	4.9	3.4	M6	6.2	0.25	0.43	0.67
1	73.8	1.6	0.26	1	0.12	0.10	3.0	3.0	6.8	3.9	4.7	4.9	3.4	M6	6.2	0.25	0.43	0.67
2	147.5	1.6	0.33	1.2	0.12	0.10	3.5	3.5	7.6	4.7	5.5	5.7	4.1	M8	6.6	0.33	0.55	0.67
3	368.8	1.6	0.51	1.6	0.12	0.12	4.3	4.3	9.0	6.1	6.9	7.1	5.2	M12	7.3	0.51	0.79	0.67
3	737.6	1.6	0.51	1.6	0.12	0.12	4.3	4.3	9.0	6.1	6.9	7.1	5.2	M12	7.3	0.51	0.79	0.67
4	1,475.2	1.7	0.63	1.7	0.12	0.16	5.5	5.5	10.4	7.5	8.3	8.4	6.5	M14	8.0	0.59	0.87	0.67
4	2,212.8	1.7	0.87	2.2	0.12	0.16	5.5	5.5	10.4	7.5	8.3	8.4	6.5	M14	8.0	0.59	0.87	0.67
5	3,688	2.5	0.83	2.5	0.12	0.16	6.9	6.9	12.3	9.4	10.0	10.2	8.1	M18	8.9	0.75	1.2	1.3

4504A_000-598a-11.07

Electrical Connections

Pin Allocation of the 12-Pin Built-in Standard Connector A

Function	PIN	Description
Supply	F A	+U _B Ground relating to +U _B
Shield	M	In the sensor on housing
Torque output	C	U _A /F _A 0±10 V (Opt. B1) 100±40 kHz (Opt. B2) 60±20 kHz (Opt. B3) 10±5 kHz (Opt. B4) Ground relating to U _A
Speed pulses	D	SGND
	H	Track A
	G	Track B
100% control input	J	Control
	K	Control
		Control
RS-232C interface to the UMV 3000	B L	TXD RXD
Digital ground	E	DGND

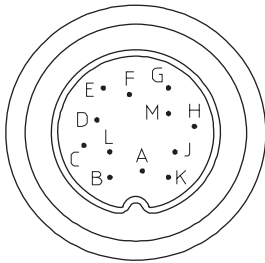

Pin Allocation of the 7-Pin Built-in Standard Connector B

Function	PIN	Description
–	1	n.c.
–	2	n.c.
Digital mass potential	3	DGND
100% control input	4	Control
RS-232C interface	5	TXD
	6	RXD
	7	OGND

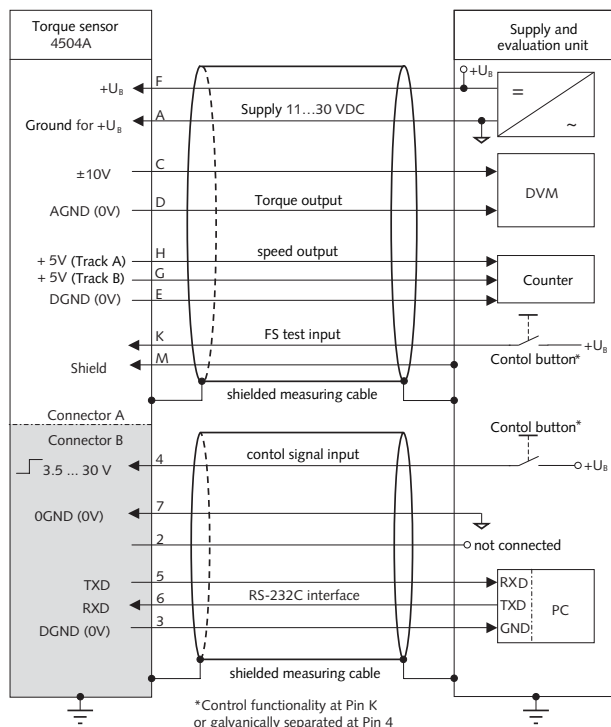
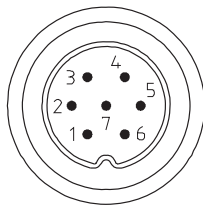

4504A_000-598a-11.07

Fig. 1: Pin allocation of the built-in connector A and B (standard)

Electrical Connections

Pin Allocation of the 7-Pin Built-in Connector C, Option P

Designation	Voltage	Frequency	PIN	Description	
				Voltage	Frequency
AGND		F_A /AGND**	1	Ground relating to U_A	F_A amplitude: 5 VDC RS-422/**Reference point for 12 VDC amplitude
GND			2		$+U_B$
$+U_B$			3	$+11 \dots +30$ VDC, power input 4 W	
U_A		F_A	4	$0 \dots \pm 10$ V	F_A
n.c.		AGND	5	Reference point for U_A	Ground relating to F_A (at RS-422 for F_A)
Control			6	Potential free control input Off: $0 \dots 2$ VDC/ On: $3.5 \dots 30$ VDC, $R_{i,K} = 10$ k Ω	
OGND			7	Ground relating to control	

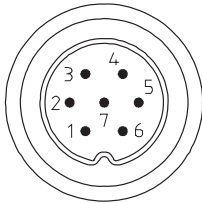

Pin Allocation of the 8-Pin Built-in Connector D, Option P

PIN	Description
1	Track A RS-422, double frequency TTL signal **
2	not connected
3	Track B RS-422
4	not connected
5	not connected
6	Track A RS-422
7	Track B RS-422 signal for direction of rotation **
8	DGND

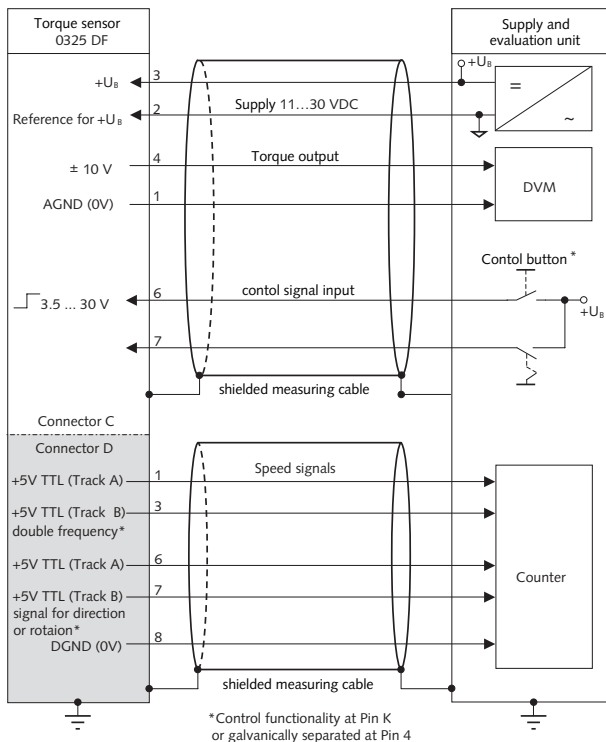
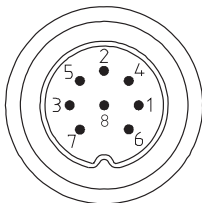

** Selectable within sensor

$F_A =$ 100±40 kHz (Opt. B2)
60±20 kHz (Opt. B3)
10±5 kHz (Opt. B4)

4504A_000-598a-11.07

Fig. 2: Pin allocation of the built-in connector C and D (option B5 or B6)

Mounting

Threaded Joint of Rotor, Fastening Bolts

Nominal torque M_{nom}	lbf-ft	36.9	73.8	147.5	368.8	737.6	1,475.2	2,212.8	3,688
Thread		M6	M6	M8	M12	M12	M14	M14	M18
Quality class		10.9	10.9	10.9	10.9	10.9	10.9	10.9	10.9
Min. mounting depth	in	0.24	0.24	0.32	0.51	0.51	0.63	0.83	0.89
Max. mounting depth	in	0.59	0.59	0.63	0.87	0.87	1.0	1.2	1.4
Fastening torque M_{fast}	lbf-ft	10.3	10.3	25.1	73.8	84.8	136.5	136.5	295
Balancing class	Q	6.3							
Counterflange flatness	in	0.0004							
Counterflange concentric.	in	0.0008							
Max. delay rotor to stator									
Axial	in	±0.039							
Radial	in	±0.079							

Important: mounting depth has to be strictly observed!

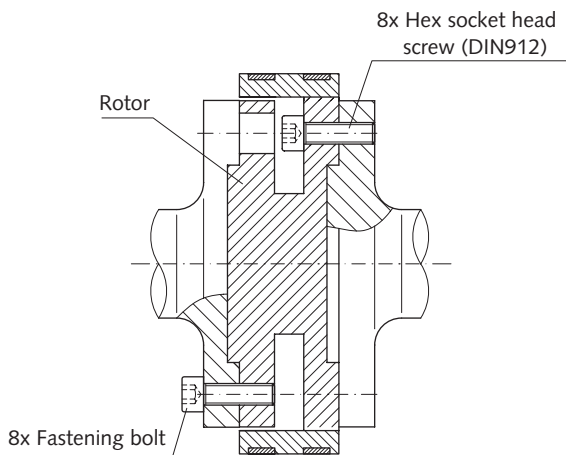

Application Examples

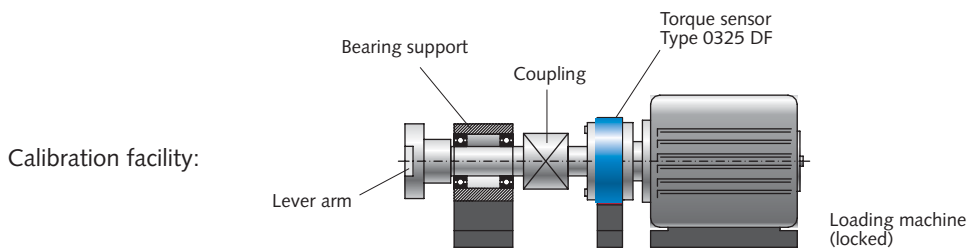
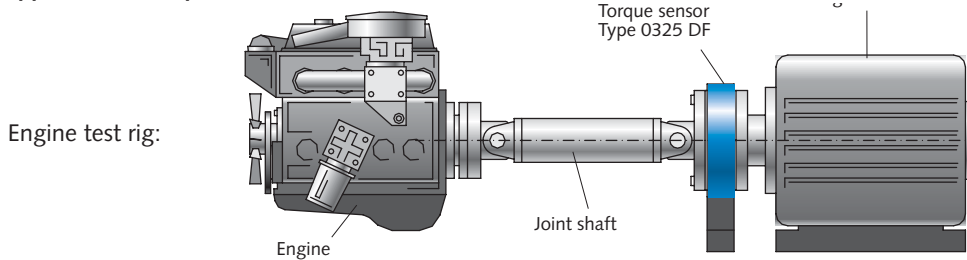

4504A_000-598a-11.07

Included Accessories

- None

Optional Accessories

- | | Type/Art. No. |
|---|----------------------|
| • Connection cable, 5 m | KSM007203 |
| • Connection cable, 5 m, 12 pin – open ends | KSM012497 |
| • Connection cable, 5 m, 7 pin – open ends | KSM021971 |
| • Connection cable, 2.5 m,
12 pin – UMV 3000 | KSM018642 |
| • Female connector 7 pin (plug C) | KSM000517 |
| • Female connector 8 pin (plug D) | KSM013136 |
| • UMV 3000 Supply and evaluation
instrument | 4700A... |
| • Adapter flanges (on request) | |
| • Couplings (on request) | |
| • Sensor Tool ST 2006 | 4706A... |

Our torque calibration service lab DKD-K-37701 offers traceable recalibration of any brands.

For further information of cable and connector see data sheet KSM_000-615.

Order example without options: Type 4504A1KB100000N1

Torque sensor: rated torque **737.6** lbf-ft,
Analog output 0±10 V
Speed measurement with 1x60 pulses

Order example with options: Type 4504A1KB20D10N2

Torque sensor: rated torque **737.6** lbf-ft, **B2**: Frequency output 100±40 kHz, **0**: Without increased output, **00**: Without interface, **N2**: Speed measurement with 2x720 pulses (100 ± 40 kHz)

Ordering Key**Measuring Ranges in lbf-ft***

36.9	50
73.8	100
147.5	200
368.8	500
737.6	1K
1,475.2	2K
2,212.8	3K
3,688	5K

Output Signal*

Analog output 0±10 V	B1
Frequency output 100 ± 40 kHz	B2
Frequency output 60 ± 20 kHz	B3
Frequency output 10 ± 5 kHz	B4

Increased Accuracy

Without	0
Increased accuracy	C

Interface

Without	00
RS-232C calibration	D1

Connector

Without	0
Connector C + D	P

Speed*

Speed measurement with 60 pulses	N1
Speed measurement with 2x720 pulses	N2
Speed measurement with 2x1 024 pulses	N3

* One option has to be defined.

Type 4504A

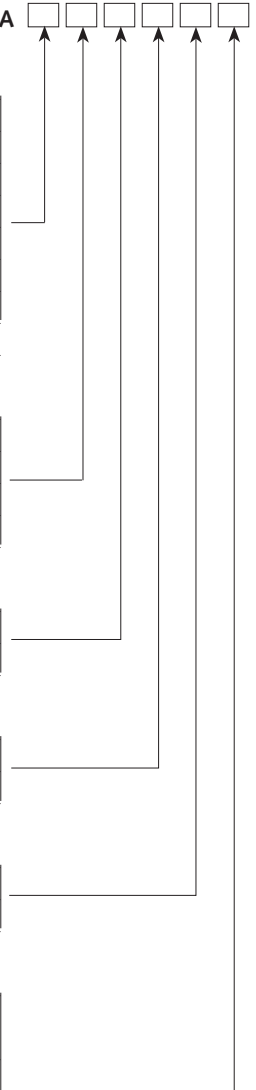

Schlenker Enterprises, Ltd.
PO Box 9277, Lombard, IL 60148, USA
Phone: 708-449-5700
Fax: 708-449-5703
www.schlenkent.com
e-mail: sales@schlenkent.com